

## The effect of presence on human-robot interaction

Wilma A. Bainbridge, Justin Hart, Elizabeth S. Kim, and Brian Scassellati

**Abstract**— This study explores how a robot's physical or virtual presence affects unconscious human perception of the robot as a social partner. Subjects collaborated on simple block-moving tasks with either a physically present humanoid robot or a video-displayed robot. Each task examined a single aspect of interaction: greetings, cooperation, trust, and personal space. Subjects readily greeted and cooperated with the robot in both conditions. However, subjects were more likely to fulfill an unusual instruction and to afford greater personal space to the robot in the physical condition than in the video-displayed condition. The same tendencies occurred when the virtual robot was supplemented by disambiguating 3-D information.

### I. INTRODUCTION

IMAGINE a team of human and robotic astronauts, cooperatively repairing a spacecraft. Each member of the team contributes a set of uniquely specialized capabilities, and each must rely on the others' expertise. Are there aspects of the robotic astronaut's design which can facilitate the human astronaut's sense of trust and respect for the robot? If the robotic astronaut must work remotely from its human teammates, will its remote presence affect the cooperative interaction?

This sort of scenario, where humans must work closely with robots in sometimes social situations, is becoming increasingly relevant in today's world [1]-[3]. In this paper we ask, what aspects of a robot or agent's design affect human willingness to interact with the robot? How does physical embodiment, as opposed to virtual presence, affect human perception of social engagement with an artificial agent?

Previous work using questionnaires has shown that embodied robots are consistently perceived as more engaging than a character on a video display, and sometimes as engaging as a human [4],[5]. In Kidd and Breazeal's [6] block-moving task, subjects were instructed by an agent, which showed only its eyes to the subjects. The eyes belonged either to a human, a robot, or a cartoon robot. All three visual presentations were accompanied by the same vocal instructions. Subjects' perceptions of engagement with the agent were measured using a questionnaire based on a previous, presence-measuring questionnaire [7], which subjects completed after the task.

W. A. Bainbridge, J. Hart, E. S. Kim, and B. Scassellati are with the Social Robotics Laboratory, Department of Computer Science, Yale University, New Haven, CT 06520 USA (phone: 240-277-7895; e-mail: wilma.bainbridge@yale.edu, justin.hart@yale.edu, eliskim@cs.yale.edu, scasz@cs.yale.edu).

We suggest that while a post-hoc questionnaire captures a subject's explicit reflections on her perceptions, her interaction-immediate behavior might be a more direct measurement for her unconscious perceptions of social engagement. Reeves and Nass [8] showed that when computer-users evaluated a computer's performance, and typed the evaluation on the same computer being evaluated, they were significantly less negative than if they typed on a different computer, indicating some unconscious consideration for a computer's "feelings."

The study of presence is relevant to many aspects of robotics [9]. Other studies have focused on the effects of physical presence on human learning of a robotic tool. For instance, when humans learn to operate a robotic arm, under three distinct conditions—learning from interaction with the robotic arm itself, from live video feed of the robotic arm, or from a graphical animation of the robotic arm—people learn equally well from the animated and physical arm, and they learn even better from the live video feed [10].

Our present study takes a more socially-relevant approach to studying robotic presence, and incorporates both implicit and explicit subjects' reactions to the robot. Other studies have used such a combination to examine comfort in human-robot interaction [11],[12]. For this study, we choose to specifically examine social interactions requiring trust and respect because they are fundamental to many other social interactions including cooperation, which is a major application field for robotics.

### II. METHODOLOGY

#### *Experimental Design*

The present experiment was designed to investigate conscious and unconscious effects of the physical versus video-displayed presence of a robot in a human-robot interaction task. The interactive task involved a humanoid robot's use of pointing gestures to direct subjects to move books to various places in an office environment that could allow for social interpretation.

1) *Experimental Groups*: Sixty-five undergraduates, graduate students, and university administrative staff participated as subjects in this experiment. None of the subjects had ever met Nico [13], the robot used for this experiment, and their fields of study were diverse, ranging from physics to history. When asked about their experience with robotics on a scale from one to seven (one meaning

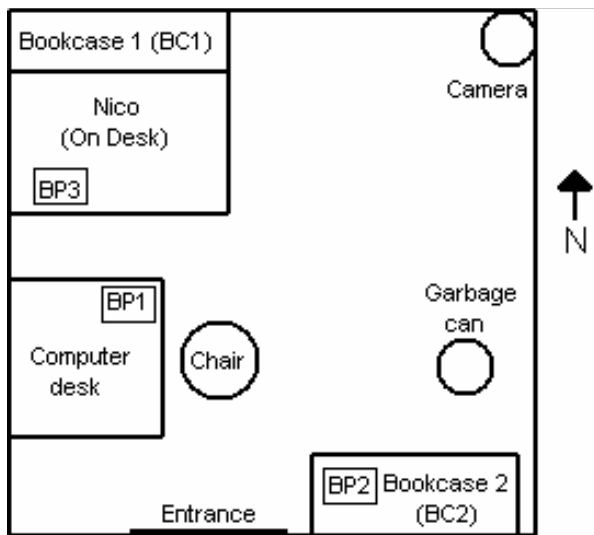

Fig. 1. Schematic drawing of the experimental setup. BP denotes each book pile.

unfamiliar), the mean score was 1.9, and no subject answered above five. The subjects for this experiment were divided into three groups: one group interacted directly with the robot (the *physical* condition), one group interacted with a live video feed of the robot on a flat-panel LCD monitor (the *virtual* condition), and a third group interacted with the same live video feed of the robot, but also were presented with a second monitor showing an overhead view of the office task environment and robot (the *augmented-virtual* condition). This third condition was examined after the first two, and aimed to disambiguate the targets of pointing gestures in the virtual condition by providing additional three-dimensional information. Twenty-two subjects participated in the physical condition, 22 subjects in the virtual condition, and 21 subjects in the augmented-virtual condition. Due to technical problems which disrupted task completion, such as network or robot failure, the data for two subjects for the physical condition, two subjects for the virtual condition, and two subjects for the augmented-virtual condition were discarded, leaving 20 measurable subject data points in the physical condition, 20 in the virtual condition, and 19 in the augmented-virtual condition. Genders were balanced in all three conditions.

2) *Environment Setup*: The office environment, an 8' x 8' space containing two desks, two bookshelves, and a garbage can, was enclosed within walls made from movable partitions. During the physical condition, the office environment was constructed around the robot's physical platform, whereas in the virtual and augmented-virtual conditions, the office environment was set up within a nearby office, distant enough to provide isolation from the confusing sound of the physical robot's moving parts. For all three conditions, the furniture and layout within the office environment were arranged identically.

Fig. 1 shows a floor-plan representation of the office environment. Each subject was initially seated at a small

workstation facing the "west" wall. The robot (or the LCD monitor on which the robot appeared) was situated on a desk to the subject's right. The robot/monitor was easily visible while the subject performed tasks at the computer workstation. The room also contained two bookcases, one placed directly behind the robot/monitor on the north wall (BC1) and one located behind the workstation at the southeast corner (BC2). Both bookcases were easily accessible. Three piles of books were placed in the office environment: next to the computer (BP1), on the southeast bookcase (BP2), and in front of the robot (BP3). A garbage can was placed beside the second bookshelf (BC2).

Two cameras were used for data collection. A digital camcorder was placed at the northeast corner of the room to film the overall experiment. A second camera was mounted on the ceiling, to allow measurement of the distance between the subject and the robot. A microphone was also placed in the room so that the experimenter could hear any utterances from the subject. Subjects consented beforehand to being filmed for the experiment.

Two further cameras were used for the interaction in the virtual and augmented-virtual conditions with the video-displayed robot. One webcam was used to record the robot's actions for video-feed to the subject, and a second camera was placed directly above the video-display monitor in the laboratory setup to record the robot's point of view.

3) *The Robot Nico*: The robot used throughout this experiment was an anthropomorphic upper-torso robot designed with the proportions of a one-year old child, named Nico [14]. Although Nico's construction is not concealed, Nico has a friendly, non-threatening face. The robot wore a (child's) sweatshirt and baseball cap during the interactions (see Fig. 2). Nico's head has a total of seven degrees of



Fig. 2. The upper-torso robot Nico inside the laboratory setup.

freedom (DOFs) including separate yaw and simultaneous pitch for both eyes [15]. The arms have six DOFs each, two at the shoulder, elbow and wrist respectively. All arm and head joint angles are constrained to represent the abilities of a one-year-old child. Each eye is equipped with two miniature CCD cameras, one for foveal and one for peripheral vision.

A set of non-verbal scripted behaviors were designed for the robot. These behaviors included task-based functional behaviors (such as pointing to particular locations in the room), interactive behaviors (such as a shoulder shrug to indicate a lack of useful response), and "idle" behaviors designed to acclimate subjects to the robot's movement and to make the interaction more natural without indicating any task-relevant information. These idle gestures included: looking around, "cracking" its neck, and swinging its arms.

The robot was controlled through a custom-built remote interface that allowed an experimenter to observe the testing environment directly through the robot's cameras (mounted in its eyes) or from a small camera located above the video-displayed robot. The experimenters controlled the robot in a Wizard-of-Oz style so that the robot could be easily controlled and periodically make eye contact with the subject. The experimenters could trigger any of the scripted behavior sequences by a single button press, or could indicate a directed behavior (such as looking at a target or pointing toward a target) by indicating a point within the robot's camera image. The transformations between visual coordinates and arm-centered or head-centered coordinates were hand-tuned to ensure accuracy to any of the common locations identified in the interaction script (below).

4) *The Video Display*: For the virtual and augmented-virtual conditions, a video feed of the robot was displayed on a 20-inch LCD computer monitor, in portrait orientation, so that its length and width approximated Nico's dimensions. Video of Nico's actions was sent from Nico's physical environment using network video streaming software. The environment was set up so that there was the same amount of space for maneuvering in front of Nico in all three conditions.

For the augmented-virtual condition, a second monitor of the same dimensions was placed to the right of the monitor with the robot, on the same table. It presented a bird's-eye view of the robot inside office environment. Each of the robot's pre-scripted motions were accompanied by pre-recorded, overhead video of Nico's gestures within the office environment, providing a view that clarified which objects were indicated by its pointing gestures.

#### A. Interaction Script

1) *Introduction to the environment*: The experimenter first told each subject that he or she was helping the laboratory "examine how humans work in office environments and how artificial intelligence can help." The experimenter indicated Nico, introducing it as, "Nico, an artificial intelligence project belonging to the lab" avoiding reference to its

physical or virtual presence. The experimenter then asked the subject to sit in a chair facing the computer desk (see Fig. 1).

Subjects were shown a desktop instant messaging client on the computer and informed that they might be asked to perform additional tasks, which would be assigned by an instant message from the experimenter. Any instant messages sent by the subject received a response rephrasing the instructions.

2) *Task 1, Greeting*: As the experimenter introduced the subject to Nico, ensuring that the subject was looking at Nico, Nico waved at the subject. The subject's response to Nico's wave was noted. The experimenter left the room, and the subject was given three minutes to work on a dummy task.

3) *Dummy task*: Each subject was given a "dummy task" on the office computer, in which she had to proofread an error-ridden piece of text about general robotics. This dummy task was employed to acclimate the subject to Nico and to prevent the subject from actively considering the exact purposes of each task. During this time, Nico performed a sequence of idle gestures to acclimate the subject to its presence and to appear more lifelike. The sequence of idle gestures was identical for subjects in all conditions.

4) *Task 2, Simple task cooperation*: After three minutes, the experimenter contacted the subject with the following instant message: "We have a task for you to do. Could you please move the objects as Nico indicates to you? Do not worry about the proofreading task. Thank you." After the subject looked up from reading this message, Nico pointed to the first pile of books (BP1) in the room and then pointed to a bookshelf (BC2), upon which the subject should place the books. For every task, Nico performed a gesture a second time if the subject did not follow it the first time. After the second attempt, Nico moved onto the next gesture.

The subject's response time and action were noted. In the software controlling Nico, whenever an action for the robot was executed, a timer was simultaneously triggered. After the subject had finished completing Nico's command, a button was pressed which stopped the timer and returned the response time. Complete response time of a task was computed as the sum of the response time for grasping the books and the response time for releasing the books, including the times for a repeat of a gesture when needed..

5) *Task 3, Unusual task cooperation*: Nico next pointed to the second pile of books (BP2) in the room, and then to the garbage can. Throwing out the books was an unusual request, as it involves destruction in some sense. The subject's response action and time were noted.

6) *Task 4, Proximity task cooperation*: After the subject had moved the second pile of books, Nico pointed to the third pile of books (BP3). Then, Nico looked up and pointed behind itself to a bookcase (BC1). This task examined the amount of "personal space" the subject allowed Nico when placing books on the bookshelf behind the robot. Usually, a

human will walk around another person rather than reach over him [16]. The subject's response time and choice of allowed personal space (over or around) were noted using the overhead camera.

After this series of tasks, the experimenter returned to the office environment, thanked the subject, and asked her to move into a second room to answer the Interactive Experiences Questionnaire.

### B. Interactive Experiences Questionnaire

The survey for this study was adapted from Kidd and Breazeal's Interactive Experiences Questionnaire [6], with permission. The original Interactive Experiences Questionnaire by Lombard and Ditton [7] was developed as a standardized survey for testing presence, specifically for feelings of presence with film. The questionnaire was adapted by Kidd and Breazeal [6] to measure the perceived presence in three characters: a human, a robot, and a cartoon robot. Our study uses the Kidd and Breazeal questionnaire, except with mention of only one character (Nico) and no questions about vocal interaction. Our questionnaire also incorporated new study-specific open-ended questions, such as, "What did you think when instructed by Nico to put books in the garbage can?" Our questionnaire was developed to gain information about subjects' perceptions and feelings in relation to their interaction with Nico. Many questions ask about the "realness" of Nico and examine how engaging the interaction was. Each question is answered with a score ranging from 1 to 7. The questionnaire is divided into four sections:

1) *General impressions*, including questions such as "How engaging was the interaction," and "How often did you feel that Nico was really alive and interacting with you?"

2) *Characteristics of the interactions*, which asks subjects to rate characteristics such as Personal versus Impersonal, and rate sentences such as "He/she makes me feel comfortable, as if I am with a friend."

3) *Overall impressions*, which includes open-ended questions such as "What was missing from Nico that would make it seem more alive?"

4) *Biographical information*, which includes questions about the frequency of computer use and experience with programming and robotics.

### C. Data Collection

Data were collected from three main sources: 1) video recordings of the interaction, 2) recorded response times, and 3) subjects' written responses to the Interactive Experiences Questionnaire. The dummy task served solely as distraction from the real intention of the study, and each subject's proofreading progress was not analyzed.

## III. RESULTS

The following are the results for each task, and a comparison between the two experimental groups. See Fig. 3

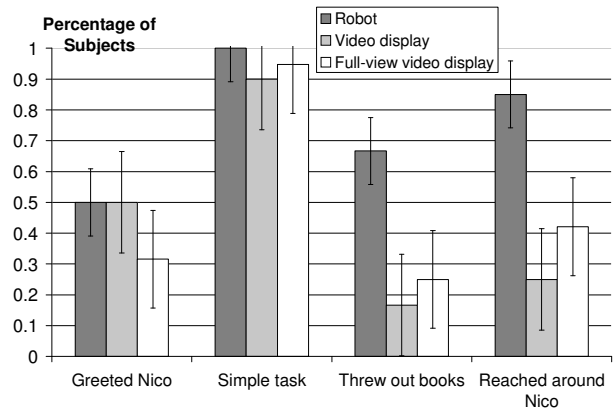

Fig. 3. Graph of the percentage of subjects who displayed specific behaviors for each task for the three conditions. For the unusual (book disposal) task, only subjects who made physical contact with or attended to the garbage can are shown in this graph. Error bars indicate standard error.

and Table I.

1) *Task 1, Greeting*: After Nico waved, ten subjects in the physical condition responded with a greeting, ten subjects in the virtual condition responded, and six subjects in the augmented-virtual condition responded, resulting in no significant difference. Greeting responses varied, ranging from verbal responses (e.g., "Hello.") directed toward Nico, to waving at Nico.

2) *Task 2, Simple task cooperation*: All 20 subjects in the physical condition correctly interpreted Nico's pointing gestures and moved a pile of books from one location, pointed out by Nico, to another. In the virtual condition, 18 subjects correctly interpreted Nico's pointing gestures, while two subjects never responded to any of Nico's gestures, despite having been introduced to Nico and having been instructed, via instant-message, to expect instructions from Nico, in accordance with our interaction script. 18 subjects in the augmented-virtual condition also correctly interpreted Nico's pointing gestures. We treated the moving of books, regardless of which specific book pile and which specific destination, as successful completion of the simple task.

The average simple task response time was 20.5s. for the physical condition, 27.09s. for the virtual condition, and 19.73s for the augmented-virtual condition. An analysis of variance indicated a significant difference in these three sets of response times,  $F(2,33)=3.321$ ,  $p<.05$ , possibly caused by the difficulty in interpreting 3-D gestures in the virtual condition.

3) *Task 3, Unusual task cooperation*: In all three conditions, subjects expressed hesitation or confusion at the request to place the books in the garbage can. Many subjects giggled or glanced multiple times from the robot to the garbage can during the instructions. Twelve subjects in the physical condition placed the books in the garbage can, while only two subjects in the virtual condition and three subjects in the augmented-virtual condition placed the books in the garbage can. This represents a significantly higher tendency for those in the physical condition compared to the virtual condition to throw out the books,  $t(38)=3.794$ ,

$p < .001$ . Even with disambiguating 3-D information, the physical condition still showed this higher tendency compared to the augmented-virtual condition,  $t(37) = 3.101$ ,  $p < .005$ .

Even when we consider only those subjects who attended to or made physical contact with the garbage can (18 subjects in the physical condition, 12 in the virtual condition, and 12 in the augmented-virtual condition), indicating a correct interpretation of Nico's gesture, a significantly higher number of subjects put the book in the garbage can in the physical condition, compared to the virtual condition,  $t(28) = 2.982$ ,  $p < .01$ , and compared to the augmented-virtual condition,  $t(28) = 2.366$ ,  $p < .05$ .

The average response times were 17.8s for the physical condition, 42.18s for the virtual condition, and 19.2s for the augmented-virtual condition. There was a significant difference in the response times of the three conditions,  $F(2,33) = 10.18$ ,  $p < .001$ .

4) *Task 4, Proximity task cooperation:* In the physical condition, 17 subjects walked around Nico when placing the books on the shelf behind it. Three from the same group reached over Nico. In contrast, in the virtual presence condition, only five subjects walked around Nico, while 11 reached over (and four did not approach Nico, possibly because they did not understand the gesture). Similarly in the augmented-virtual condition, eight subjects walked around Nico, while 11 reached over. This represents a significantly higher tendency to walk around Nico in the physical condition rather than the virtual condition,  $t(34) = 3.819$ ,  $p < .001$ , and the augmented-virtual condition,  $t(37) = 3.04$ ,  $p < .005$ .

For the physical condition, the average response time was 26.1s, for the virtual condition, it was 32.09s, and for the augmented-virtual condition, it was 24.2s, with no significant difference.

5) *Questionnaire results:* Many questionnaire items addressed the subject's perception of Nico as a social creature. Table I shows all questionnaire results that differed significantly between the physical and virtual conditions. The virtual data also includes the augmented-virtual condition data, as the important comparison is between the type of presence of Nico (physical or virtual). Subjects found

TABLE I  
SIGNIFICANT QUESTIONNAIRE DATA

	Robot Average	Virtual & Augmented- virtual Average	$p$
How natural was the interaction?	<b>4.2</b>	3.2	0.006
Homogeneous	3.11	<b>4.17</b>	0.030
Negative	1.42	<b>2.28</b>	0.004
Varied	2.63	<b>3.89</b>	0.017

$n = 59$ , results of a two-tailed t-test,  $\alpha < .05$ . The higher average for each set is bolded. Each question was answered on a scale from 1 to 7.

the interaction with the physical robot very natural, while video display subjects thought of Nico as negative, homogeneous and varied.

The questionnaire also asked subjects, "What did you think when instructed by Nico to put books in the garbage can?" Subjects' responses mirrored the data. Subjects in the physical condition sometimes found the request unusual, but these subjects still complied. For example, one physical condition subject stated, "I did not really think about it too much. He seemed to know what to do, so I just obeyed." No physical condition subject mentioned understanding the command but not following it. Subjects in the virtual and augmented-virtual conditions also expressed confusion at the request, but often did not follow it. For example, one video-displayed robot subject stated, "I put them on the shelf. The garbage can is for trash." A subject in the augmented-virtual condition stated, "I thought that may have been where he was pointing, but it seemed unlikely you would want me to throw away books, so I shifted it to that area of the desk."

#### IV. DISCUSSION

Subjects were excited to interact with both the physical robot and the video-displayed robot. There was no significant difference in greeting reciprocation among the three conditions; subjects waved to both the actual robot and the video-displayed robot. The simple task was able to establish the book-moving paradigm for the experiment. Although subjects in the virtual group at first had difficulty understanding which pile of books to move, most subjects (90%) moved a pile of books to another location with Nico's instruction. The augmented-virtual condition improved upon the ambiguity in the pointing gestures of a virtual robot.

Most subjects indicated they were confused by the garbage can placement task, as it is an unusual request. However, many subjects in the physical condition still placed books in the garbage can. Even restricting consideration to those subjects who recognized the garbage can gesture, significantly more subjects in the physical condition threw out the books. This could indicate that physical presence afforded higher trust in Nico's credibility, making subjects more willing to follow through with an unusual request from Nico.

Many subjects in the virtual condition had difficulty accurately completing each task, taking much longer than the physical condition subjects. The addition of 3-D information in the augmented-virtual condition lowered subjects' response times, rectifying the ambiguity of the virtual condition's gestures. However, there were no significant differences in the response actions between the virtual and augmented-virtual conditions. This indicates that even when a subject can correctly interpret the location target of a pointing gesture, the absence of physical presence still affects the subject's interaction with the robot.

The questionnaire data also show that subjects in the physical condition found the interaction significantly more engaging. In the open-ended question about the garbage can

task, many subjects in the physical condition responded with less concern about the unusual nature of the task than did virtual and augmented-virtual participants. For example, one subject in the physical condition wrote, "I was mostly amused. It didn't seem logical to throw the book away," Yet this subject still ultimately threw out the book. Subjects in the virtual and augmented-virtual conditions tended to view Nico as more negative, and their questionnaire responses reflected a resistance to throwing out the books, with responses such as, "It was confusing because it's not typical to be directed to put things in the trash. It's not usually possible in most contexts". This combination of immediate, behavioral data and post-interaction, explicitly reflective data indicates that subjects afford greater trust to the physical versus video-displayed robot.

The proximity task may reflect the amount of respect subjects afford to the robot. Almost all subjects in the physical condition walked around Nico to place the book, instead of reaching over Nico. These results seem to indicate that subjects consider personal space when interacting with Nico. In the virtual and augmented-virtual conditions, almost all subjects reached over Nico to place the book. Although this is the shortest distance to the shelf, this is rarely a gesture a person would ever perform over another, as it clearly encroaches on both peoples' personal spaces. Some subjects even grabbed the robot's monitor in the virtual and augmented-virtual conditions, which would have been a clear violation of personal space if done to another person. Both setups allowed identical amounts of space to maneuver in front of the robot. However, subjects clearly gave greater space to the physically present robot. Whether or not this can be interpreted as a matter of personal respect, it has implications for the design of human-robot interactions.

## V. CONCLUSION

Overall, it appears that the level of a robot's presence affects some variables in human-robot interaction that should be important to consider when creating a human-robotic social interaction. The clearest way to examine presence is in the physical sense: interacting with a robot in the same room versus interacting with a video-displayed robot. Changes in physical presence impact social aspects of presence as well. Although subjects enjoyed interacting with both the physical robot and the video-displayed robot, they clearly gave the physically present robot more personal space. Personal space could be interpreted as a variable of respect; as humans give personal space to those they are unfamiliar with but respect as human. Subjects in the physical condition were also more compliant when directed to place a book in the garbage can, which suggests greater trust afforded in the case of physical presence. Along with this, subjects rated the interaction with the physical robot more positively than the video-displayed robot, suggesting generally better human interactions with a physically present robot.

Ultimately presence is a crucial variable to consider when

developing human-robot interactions, because of its effects on many dimensions of any interaction, including trust and respect.

## REFERENCES

- [1] Sidner, C. L., Lee, C., Kidd, C., Lesh, N., Rich, C. 2005. Explorations in engagement for humans and robots. *Artificial Intelligence* 166 (1-2), 140-164.
- [2] Rehnmark, F., Bluethmann, W., Mehling, J., Ambrose, R. O., Diftler, M., Chu, M., and Necessary, R. 2005. Robonaut: The 'Short List' of Technology Hurdles. *Computer* 38(1), 28-37.
- [3] Goetz, J. and Kiesler, S. 2002. Cooperation with a robotic assistant. *Conference on Human Factors in Computing Systems (2002)*, 578-579.
- [4] Burgoon, J. K., Bonito, J. A., Bengtsson, B., Cederberg, C., Lundeberg, M., and Allspach, L. 2000. Interactivity in human-computer interaction: a study of credibility, understanding, and influence. *Computers in Human Behavior* 16 (6), 553-574.
- [5] Jung, Y. and Lee, K. M. 2004. Effects of physical embodiment on social presence of social robots. *Presence 2004: The Seventh International Workshop on Presence, Spain*.
- [6] Kidd, C. D. and Breazeal, C. 2004. Effect of a Robot on Human Perceptions. *Proceedings of 2004 IEEE/RSJ International Conference on Intelligent Robotics and Systems, Japan*.
- [7] Lombard, M., Ditton, T. B., Crane, D., Davis, B., Gil-Egui, G., Horvath, K., and Rossman, J. 2000. Measuring presence: A literature-based approach to the development of a standardized paper-and-pencil instrument. *Presence 2000: The Third International Workshop on Presence, Netherlands*.
- [8] Reeves, B. and Nass, C. 1996. *The Media Equation: How People Treat Computers, Video-displayed, and New Media Like Real People and Places*. Center for the Study of Language and Information.
- [9] Ijsselstein, W. and Harper, B. 2001. *Virtually There? A Vision on Presence Research*. *Presence-1st 2000-31014 Ec Public Deliverable*.
- [10] Tzafestas, C. S., Palaiologou, N., and Alifragis, M. 2006. Virtual and remote robotic laboratory: Comparative experimental evaluation. *IEEE Transactions on Education* 49 (3), 360-369.
- [11] Powers, A., Kiesler, S., Fussell, S., and Torrey, C. 2007. Comparing a computer agent with a humanoid robot. *Proceedings of 2004 ACM/IEEE International Conference on Human-robot Interaction, Washington D.C.*, 145-152.
- [12] Yamato, J., Brooks, R., Shinozawa, K., and Naya, F. 2003. *Human-Robot Dynamic Social Interaction*. *NTT Technical Review* 1 (6), 37-43.
- [13] Crick, C. and Scassellati, B. 2006. Synchronization in social tasks: Robotic drumming. *Proceedings of 2006 IEEE International Symposium on Robot and Human Interactive Communication, UK*.
- [14] Sun, G. and Scassellati, B. 2004. Reaching through Learned Forward Model. *Proceedings of 2004 IEEE-RAS/RSJ International Conference on Humanoid Robots, CA*.
- [15] Michel, P., Gold, K., and Scassellati, B. 2004. Motion-Based Robotic Self-Recognition. *Proceedings of 2004 IEEE/RSJ International Conference on Intelligent Robots and Systems, Japan*.
- [16] Hall, E. T. 1966. *The Hidden Dimension*. Anchor Books.
- [17] Berlyne, D. E. 1958. The Influence of Complexity and Novelty in Visual Figures on Orienting Responses. *Journal of Experimental Psychology* 55, 289-296.